



The N610i digital label press

High print quality at flexo speeds



Combines the productivity of flexo with the flexibility of digital



Scan the code to find more about Domino N610i.

Domino. Do more.

The smarter way to print labels

For label printers, the Domino **N6** I0i, with up to seven colours including opaque white, 600dpi 'native' print resolution and operating speeds up to 75m/min (246ft/min), is the only label press that combines the productivity of flexo printing with the flexibility offered by rapid job change digital technology.

This means an investment that provides added potential for greater sales growth and increased profitability, whilst reducing production cost and complexity.

Applications

The **N6** I0i uses vibrant UV curable inks designed for a range of industry standard self-adhesive label stocks including coated paper, polypropylene and polyethylene. Applications include industrial, personal care, security, health and safety, automotive, chemical, pharmaceutical, food* and beverage*.

Textures by Domino **NEW**

Increased shelf edge appeal is achieved due to the highly reflective nature of the print. Unique digital textured effects can open up new applications for Domino **N6** I0i press owners.

Unique textured labeling is achievable up to 50m/min (164ft/min) using the Domino **N6** I0i. This feature enables standard coated paper, PP and PE materials to be turned into textured materials.

*Subject to an effective migration barrier being in place.

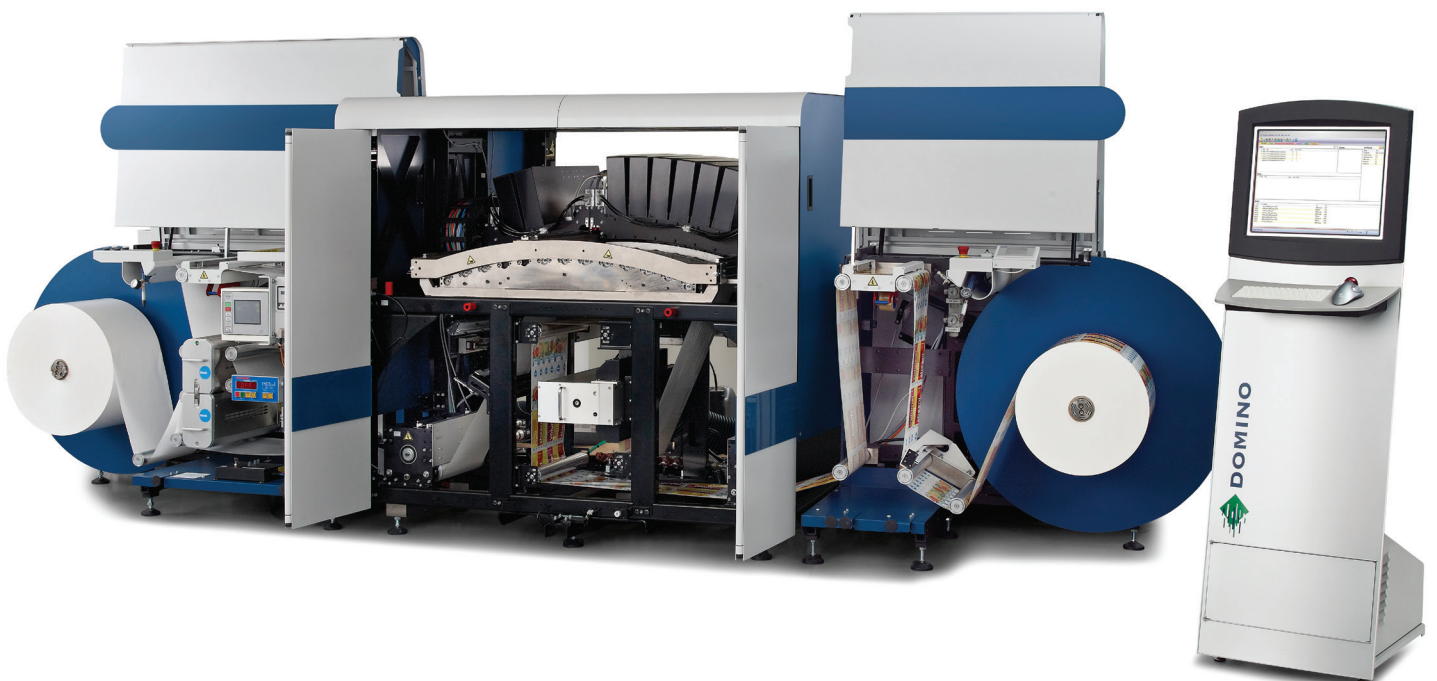
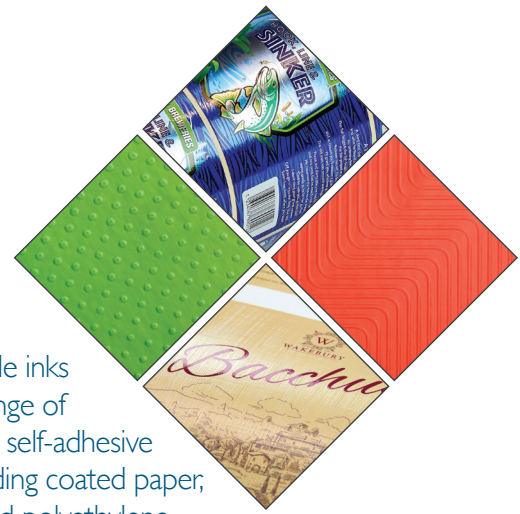

The highest digital productivity

Production capacity

With a 1m (40") diameter roll unwind capable of handling up to 340mm (13.4") wide media and the widest print width (333mm or 13.11") of any Kyocera based label press; the **N610i** can process up to 3000 linear metres (9842 linear feet) or 1000m² (10760 ft²) of material per hour in high quality mode.

Printing at speed

The high quality mode can print >90% of Pantone colours plus high opacity white at 50m/min (164ft/min). In rapid mode, the **N610i** prints up to 75m/min (246ft/min).



In-line finishing

Does your job structure suit online/offline finishing? The **N610i** has been designed to work as a standalone reel-to-reel press or has the option to be interfaced with industry leading digital finishing solutions including those from A B Graphic International, GrafiskMaskinfabrik, CEI and Delta Industries.

Customer Quote

"Scrap and labor savings, since moving this job to the Domino, is huge. With the Domino we can run in ONE HOUR what we used to run in an entire shift on flexo. We have only been running it for one month and we have already seen an increase in sales because of the Domino **N610i**."

Dave Ferguson,
President, McCourt Label, US

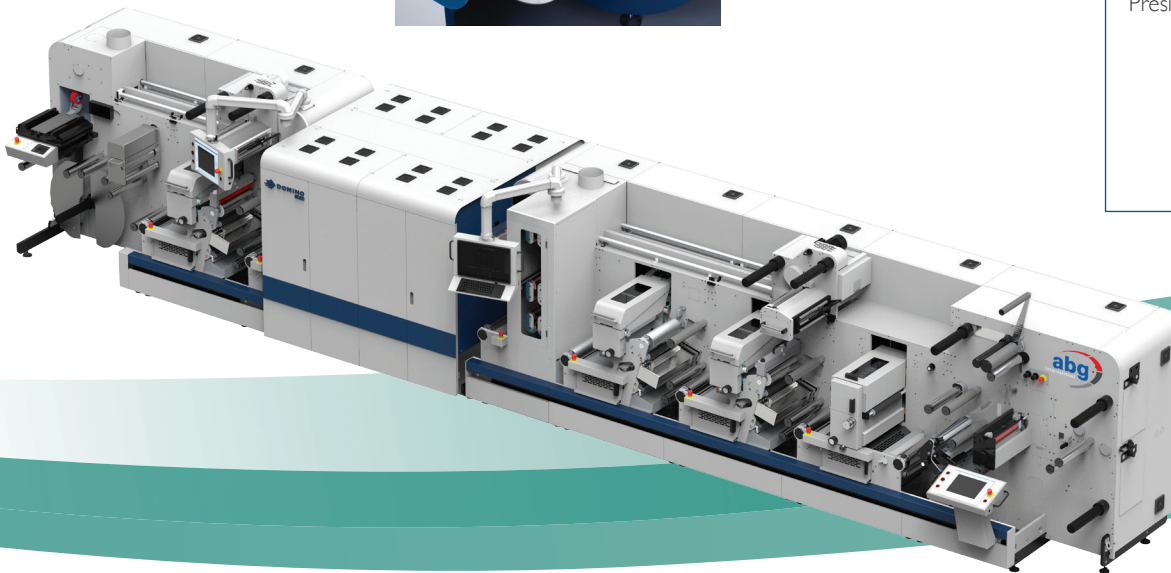

The **N610i** Integration Module

The **N610i** Integration Module can be supplied as part of a fully integrated hybrid press working with partners such as A B Graphic International, Converting Equipment International (CEI), Delta Industrial, Gonderflex and MPS.

This can include flexo stations before and after the **N610i** module as well as screen and foiling stations. This meets a wider range of product design needs but still provides digital quick change for multiple SKUs.

Customer Quote

"If we compare the productivity between traditional presses and the Domino that we have, printing the jobs is incomparable."

Christophe Quirantes,
Commercial Director, QRT Graphique, France



Greener credentials

Domino's commitment and investment in sound environmental practices means we frequently exceed the increasingly demanding governmental, industry and company standards and regulations. We are committed to minimising the

consumption of natural resources and energy and the creation of waste. Our products are RoHS and WEEE compliant so that they are recyclable.

N610i

The **N610i** requires no plates, no plate making process or associated materials for washdown purposes and with fewer curing lamps than

a flexo press, it uses less energy resulting in reduced costs.

It creates very little media waste – this can be less than 1m (40") per job and the capability to 'print-on-demand' results in less over-printing and reduced storage requirements.

The **N610i** is supplied with UV curable inks representing an efficient use of

our natural resources. Although UV curable inks are chemicals and need to be used correctly, they offer significant environmental benefits compared to solvent alternatives. Solvent inks include up to 95% volatile solvents that evaporate into the environment and require regular print head cleaning. **N610i** UV curable inks contain 1% volatile solvents.

The most consistent print results

It's just so simple

Ink jet technology is non-contact, with few moving parts, no printing plates, no drums, no blankets and no complex maintenance programmes. The time to change from printing one job to another is instantaneous with limited media waste.



Jets that keep jetting

Domino's quality controlled UV inks are constantly circulated around the print head by the innovative **i-Tech ActiFlow** ink circulation system, even when printing has stopped. **ActiFlow** degasses the ink, preventing air bubbles forming, which can impact nozzle performance.



Automated maintenance

The revolutionary **i-Tech CleanCap** automated print head cleaning and capping technology is a consistently controlled process which reduces manual operator intervention meaning that daily manual head wiping is now a thing of the past!

The best ink jet print quality

It's not just about resolution

Even though Domino uses high resolution print heads from Kyocera at 600dpi, delivering more dots per inch than most competitive systems, this alone does not deliver the best ink jet quality. To achieve this, print head integration, precise web transport, robust components ie Corona and UV, workflow and quality inks are all essential to ensure the best print results.

Customer Quote

"It is the quality of the print, the cooperation with the people and the service that we receive from our partner; as that is how we see Domino. We are capable of entering markets for which I'm 100% convinced we would not have reached if we would not have bought the Domino N610i."

Raf Joos, CEO, ASQ Labels, Belgium



Our colour range

In today's fast evolving retail marketplace, the importance of colour in product packaging cannot be over-emphasised. The **N610i** provides brand owners and designers the scope to create designs with a far wider colour gamut cost effectively. Our seven colour press can achieve in excess of 90% of the Pantone® colour range without the need to make plates or the complexity of mixing spot colours.

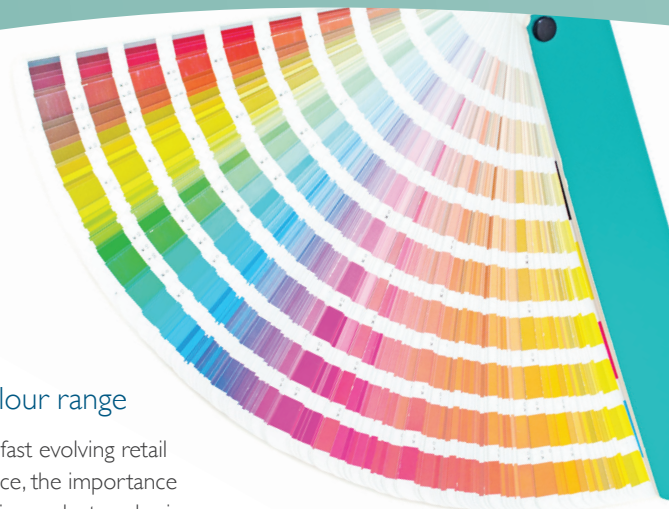

Do you print white?

Screen printing technology is the industry standard for printing tactile, high opacity white, but this is at a cost. Domino's white ink delivers a silk-screen like tactile finish and has the highest opacity in the market at over 70% when printed up to 50m/min (164ft/min), providing an efficient, cost-effective alternative to screen printing.

Take a closer look inside the N6 | 0i

– not all digital label presses are the same

intelligent Technology

i-Tech components combine to create a system altogether more flexible and reliable.

1. Domino Ink Jetting Assemblies

Proprietary Domino ink jetting assemblies incorporate Kyocera print heads that deliver consistent print results and higher reliability than any other press using similar technology



Domino

2. Ink Jet Engine

The N6 | 0i is configured in either a 4, 5, 6 or 7 colour print combination printing 333mm (13.11")

3. i-Tech CleanCap

Automated print head cleaning and capping station ensures the highest print quality and productivity – all heads are cleaned within one minute!

Kyocera

4. i-Tech ActiFlow

The ink circulation system keeps the ink continuously moving around the print head, maintaining a constant temperature and removing micro air bubbles, ensuring consistent print quality and reliability

5. i-Tech StitchLink

Micro-motor controller technology ensures that all heads are positioned precisely, calibrated to print as one, enabling seamless print across the full web width

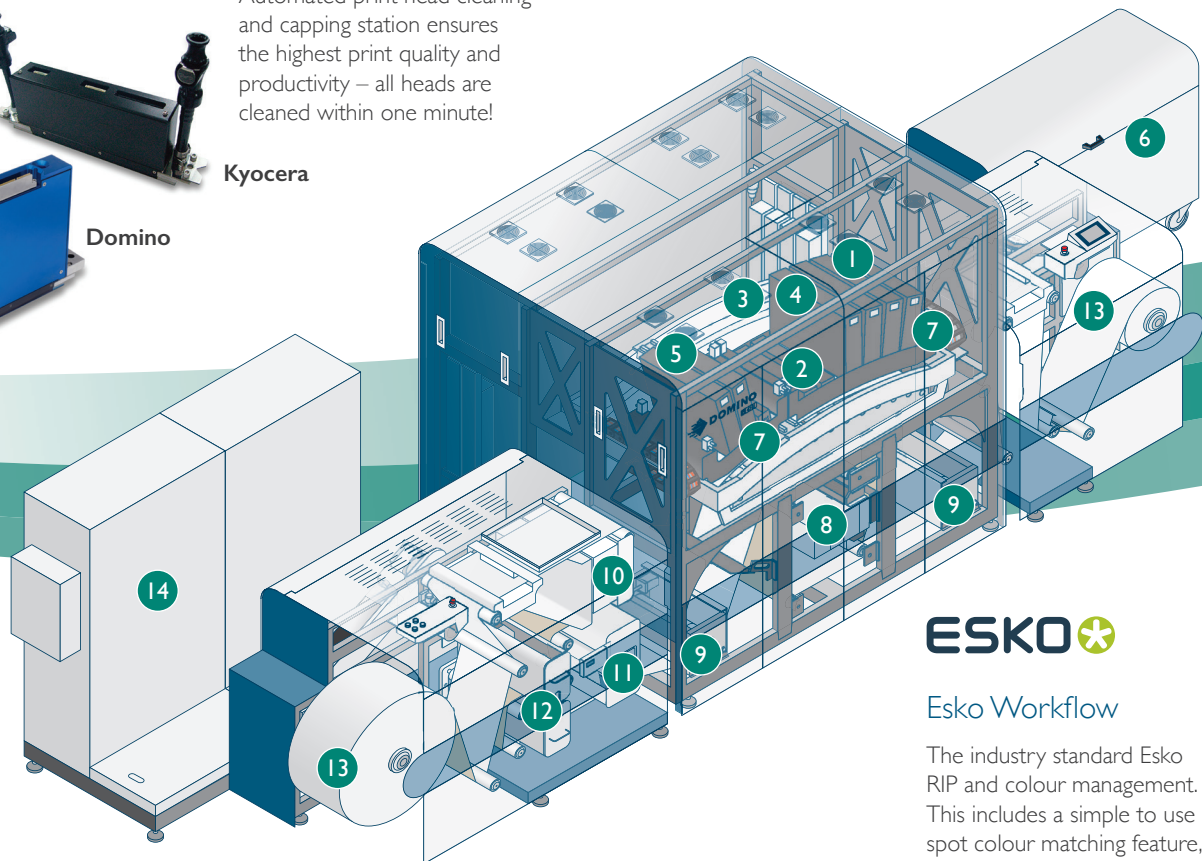

6. Ink Cabinet

7. UV LED Pinning for CMYKOV and White

8. UV Curing

GEW

9. Tension Control

10. Web Guide

FMS

11. Corona

Vetaphone

12. Web Cleaner

Teknek dual sided web cleaner

13. Unwind & Rewind

Rolls up to 1000mm (40") diameter supported. Web width between 200 - 340mm (7.9" - 13.4")

14. Temperature controlled electronic cabinet



Esko Workflow

The industry standard Esko RIP and colour management. This includes a simple to use spot colour matching feature, accurately matches your customers' colours job after job.

Variable Data Printing

With the increase in product personalisation, Domino's full colour variable data workflow using Esko not only allows variable data and images to be printed, but also ensures the colours match your non-variable jobs, even for 7 colour printing.

Technical Specification:

Technology

- Piezo Drop on Demand ink jet

Printing Speed

- Up to 50m/min (164ft/min) high quality mode
- Up to 75m/min (246ft/min) rapid mode

Image Resolution

- 600dpi native including 4 greyscales (nominal 1340dpi)

Image Format

- 333mm (13.11") maximum print width

Web Width

- 200mm (7.9") to 340mm (13.4")

Media Type

- Polyethylene, polypropylene and paper self adhesive label stock
- Selected unsupported materials (films)

Inks

- UV curable Cyan, Magenta, Yellow, Black, Orange, Violet and White

Unwind/Rewind

- 1000mm (40") diameter
- Maximum roll weight: 300kg (661lbs)
- Servo driven tension control
- Corona treatment module
- Web cleaning
- Web guide module

Workflow

- Esko DFE

Central Print Module

- Anti-static control
- 4-colour print section (CMYK standard), 5th, 6th and 7th colours (optional)
- UV LED pinning
- UV curing module

Options

- In-line finishing interface
- In-line inspection
- Variable data printing
- Load cells
- Chilled roller

Dimensions

- 5.614m (L) x 1.735m (H) x 1.925m (W) (1.0m minimum clearance required)
- 18.5ft (L) x 5.9ft (H) x 6.4ft (W) (3.3ft minimum clearance required)
- Ink cabinet: 1202mm (L) x 807mm (H) x 520mm (W) 47.3" (L) x 31.8" (H) x 20.5" (W)

Weight

- Unwind: 600kg (1323lbs)
- Printing section: Nominal 1500kg (3307lbs)
- Rewind: 400kg (882lbs)
- Power cabinet: 350kg (772lbs)
- Ink supply unit: 200kg (441lbs)

Services

- Three phase power - one 380-420V drop
- Compressed air - one drop @ 6-8 bar (90-115psi), clean and dry

Environment

- Optimal temperature range 20-22°C (68-72°F)
- Maximum temperature range 20-25°C (68-77°F)
- Ink storage 20-25°C (68-77°F)
- Optimum humidity range 40-60%
- Dust controlled environment preferred

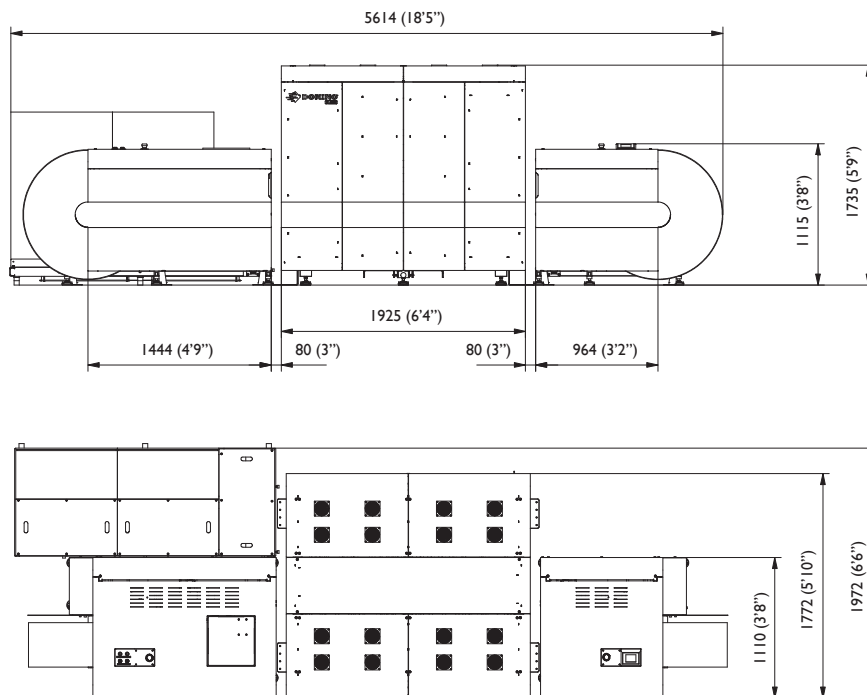

Dimensions in mm (feet/inches)

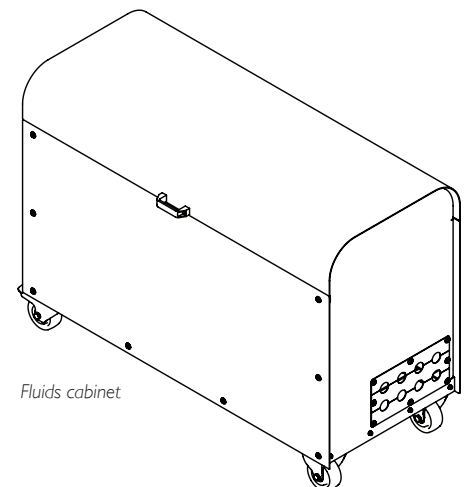

Fluids cabinet

www.n610i.com
www.domino-printing.com

YouTube

